



POWERING INNOVATION THAT DRIVES HUMAN ADVANCEMENT

© 2025 ANSYS, Inc. or its affiliated companies
Unauthorized use, distribution, or duplication is prohibited.

Classic Icepak® File Conversion



ANSYS, Inc.
Southpointe
2600 Ansys Drive
Canonsburg, PA 15317
ansysinfo@ansys.com
<https://www.ansys.com>
(T) 724-746-3304
(F) 724-514-9494

Release 2025 R2
July 2025

ANSYS, Inc. and
ANSYS Europe,
Ltd. are UL
registered ISO
9001:2015 com-
panies.

Copyright and Trademark Information

© 1986-2025 ANSYS, Inc. Unauthorized use, distribution or duplication is prohibited.

ANSYS, Ansys Workbench, AUTODYN, CFX, FLUENT and any and all ANSYS, Inc. brand, product, service and feature names, logos and slogans are registered trademarks or trademarks of ANSYS, Inc. or its subsidiaries located in the United States or other countries. Icem CFD is a trademark used by ANSYS, Inc. under license. All other brand, product, service and feature names or trademarks are the property of their respective owners. FLEXIm and FLEXnet are trademarks of Flexera Software LLC.

Disclaimer Notice

THIS ANSYS SOFTWARE PRODUCT AND PROGRAM DOCUMENTATION INCLUDE TRADE SECRETS AND ARE CONFIDENTIAL AND PROPRIETARY PRODUCTS OF ANSYS, INC., ITS SUBSIDIARIES, OR LICENSORS. The software products and documentation are furnished by ANSYS, Inc., its subsidiaries, or affiliates under a software license agreement that contains provisions concerning non-disclosure, copying, length and nature of use, compliance with exporting laws, warranties, disclaimers, limitations of liability, and remedies, and other provisions. The software products and documentation may be used, disclosed, transferred, or copied only in accordance with the terms and conditions of that software license agreement.

ANSYS, Inc. and ANSYS Europe, Ltd. are UL registered ISO 9001: 2015 companies.

U.S. Government Rights

For U.S. Government users, except as specifically granted by the ANSYS, Inc. software license agreement, the use, duplication, or disclosure by the United States Government is subject to restrictions stated in the ANSYS, Inc. software license agreement and FAR 12.212 (for non-DOD licenses).

Third-Party Software

See the legal information in the product help files for the complete Legal Notice for Ansys proprietary software and third-party software. If you are unable to access the Legal Notice, please contact ANSYS, Inc.

Conventions Used in this Guide

Please take a moment to review how instructions and other useful information are presented in this documentation.

- Procedures are presented as numbered lists. A single bullet indicates that the procedure has only one step.
- Bold type is used for the following:
 - Keyboard entries that should be typed in their entirety exactly as shown. For example, “**copy file1**” means you must type the word **copy**, then type a space, and then type **file1**.
 - On-screen prompts and messages, names of options and text boxes, and menu commands. Menu commands are often separated by greater than signs (>). For example, “click **HFSS > Excitations > Assign > Wave Port.**”
 - Labeled keys on the computer keyboard. For example, “Press **Enter**” means to press the key labeled **Enter**.
- Italic type is used for the following:
 - Emphasis.
 - The titles of publications.
 - Keyboard entries when a name or a variable must be typed in place of the words in italics. For example, “**copy filename**” means you must type the word **copy**, then type a space, and then type the name of the file.
- The plus sign (+) is used between keyboard keys to indicate that you should press the keys at the same time. For example, “Press Shift+F1” means to press the **Shift** key and, while holding it down, press the **F1** key also. You should always depress the modifier key or keys first (for example, Shift, Ctrl, Alt, or Ctrl+Shift), continue to hold it/them down, and then press the last key in the instruction.

Accessing Commands: *Ribbons*, *menu bars*, and *shortcut menus* are three methods that can be used to see what commands are available in the application.

- The *Ribbon* occupies the rectangular area at the top of the application window and contains multiple tabs. Each tab has relevant commands that are organized, grouped, and labeled. An example of a typical user interaction is as follows:

"Click **Draw > Line**"



This instruction means that you should click the **Line** command on the **Draw** ribbon tab. An image of the command icon, or a partial view of the ribbon, is often included with the instruction.

- The *menu bar* (located above the ribbon) is a group of the main commands of an application arranged by category such File, Edit, View, Project, etc. An example of a typical user interaction is as follows:

"On the **File** menu, click the **Open Examples** command" means you can click the **File** menu and then click **Open Examples** to launch the dialog box.

- Another alternative is to use the *shortcut menu* that appears when you click the right-mouse button. An example of a typical user interaction is as follows:

"Right-click and select **Assign Excitation> Wave Port**" means when you click the right-mouse button with an object face selected, you can execute the excitation commands from the shortcut menu (and the corresponding sub-menus).

Getting Help: Ansys Technical Support

For information about Ansys Technical Support, go to the Ansys corporate Support website, <http://www.ansys.com/Support>. You can also contact your Ansys account manager in order to obtain this information.

All Ansys software files are ASCII text and can be sent conveniently by e-mail. When reporting difficulties, it is extremely helpful to include very specific information about what steps were taken or what stages the simulation reached, including software files as applicable. This allows more rapid and effective debugging.

Help Menu

To access help from the Help menu, click **Help** and select from the menu:

- **[product name] Help** - opens the contents of the help. This help includes the help for the product and its *Getting Started Guides*.
- **[product name] Scripting Help** - opens the contents of the *Scripting Guide*.
- **[product name] Getting Started Guides** - opens a topic that contains links to Getting Started Guides in the help system.

Context-Sensitive Help

To access help from the user interface, press **F1**. The help specific to the active product (design type) opens.

You can press **F1** while the cursor is pointing at a menu command or while a particular dialog box or dialog box tab is open. In this case, the help page associated with the command or open dialog box is displayed automatically.

Table of Contents

Table of Contents	Contents-1
1 - Introduction	1-1
2 - Opening the Classic Icepak Project	2-1
Open the Classic Icepak Project	2-1
Set 3D UI Options	2-1
Open the Project	2-2
Classic Icepak File Conversion Limitations	2-3
3 - Reviewing the Icepak Design	3-1
Geometry and Boundary Conditions	3-1
Global Mesh Settings	3-3
Mesh Regions	3-6
Monitors	3-8
Design Settings and Solution Setup	3-10
Design Variables and Parametric Setup	3-17
Postprocessing	3-20
Fields Summary Report	3-21

1 - Introduction

This guide is intended as supplementary material to Icepak for beginners and advanced users. It includes instructions to convert a Classic Icepak project (.t3r file) into an Electronics Desktop Icepak design. This guide also reviews how elements of a Classic Icepak project are represented in Electronics Desktop.

Sample Project - Classic Icepak Project

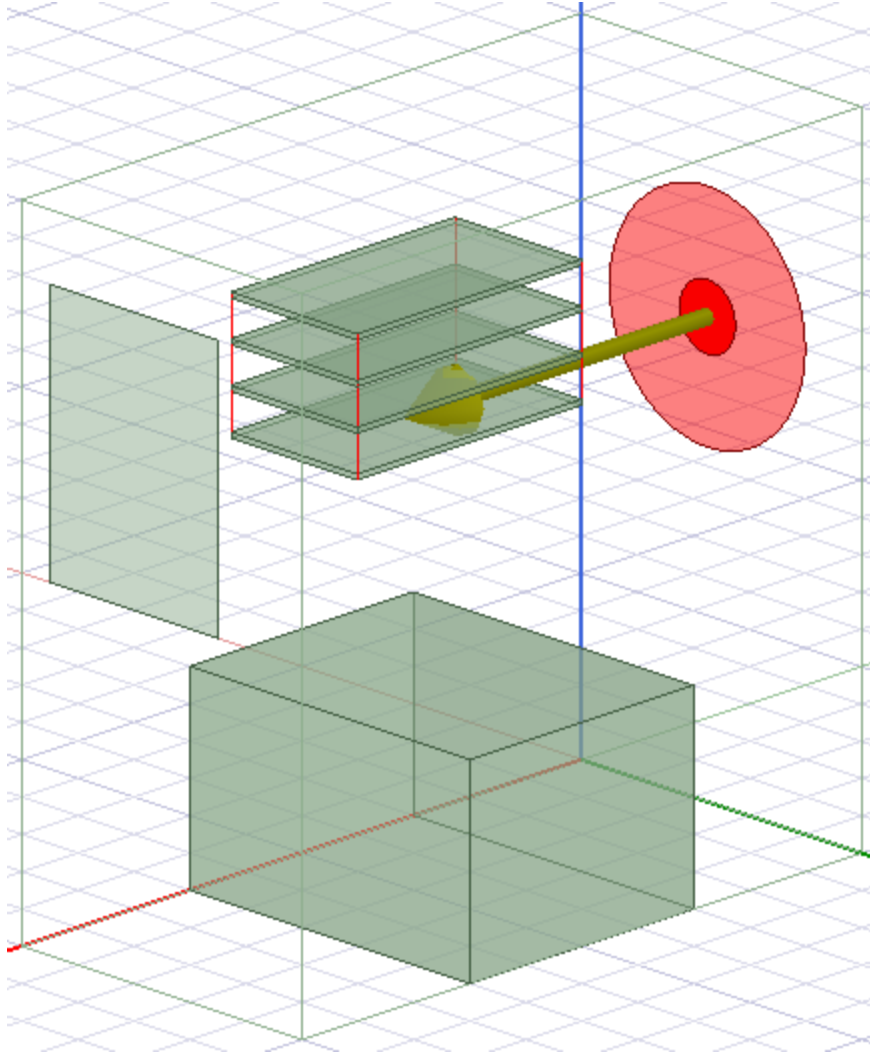

Figure 1-1: Converted Classic Icepak Project

2 - Opening the Classic Icepak Project

This chapter contains the following topics:

- [Open the Classic Icepak Project](#)
- [Classic Icepak File Conversion Limitations](#)

Open the Classic Icepak Project

A shortcut of the Ansys Electronics Desktop application appears on your desktop once the application is installed.

Set 3D UI Options

Ensure that the new view orientation scheme introduced in release 2024 R1 is not being used, since the instructions and images in this guide are based on the legacy orientation scheme.

1. From the menu bar, click **View > Options**.

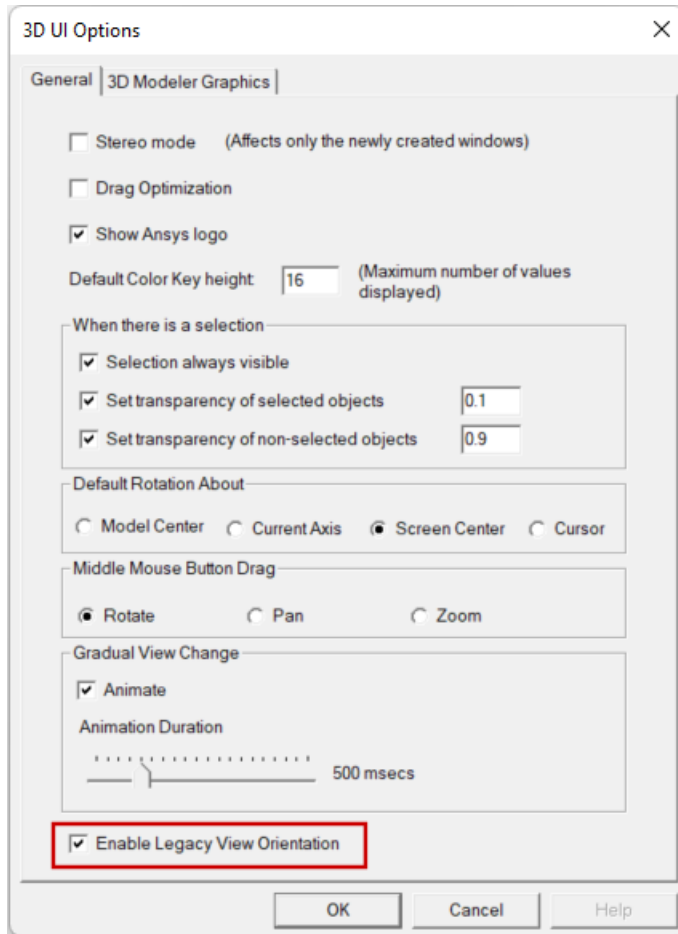

The *3D UI Options* dialog box appears.

2. Ensure that **Enable Legacy View Orientation** is enabled:



3. Click **OK**.

Open the Project

1. On the **Desktop** ribbon tab, click  **Open Examples**. Then:
 - a. In the *Open* dialog box that appears, click the parent folder icon () once to move up one level above the *Examples* folder.
 - b. Double-click the **Help** folder and then the **Icepak** folder.
 - c. From the **Files of type** drop-down list, select **Icepak Classic Project (*.tzt)**.
 - d. Select the file **ClassicIcepakProject.tzt** and click **Open**.
2. The model is displayed in the **3D Modeler** window.

Note: You can hide the grid by selecting **View > Grid Settings** and then selecting **Hide** in the **Grid Spacing** dialog box. Also, from the **View > Coordinate Systems** menu, you can hide the large coordinate triad and display a smaller coordinate triad in the bottom of the **3D Modeler** window.

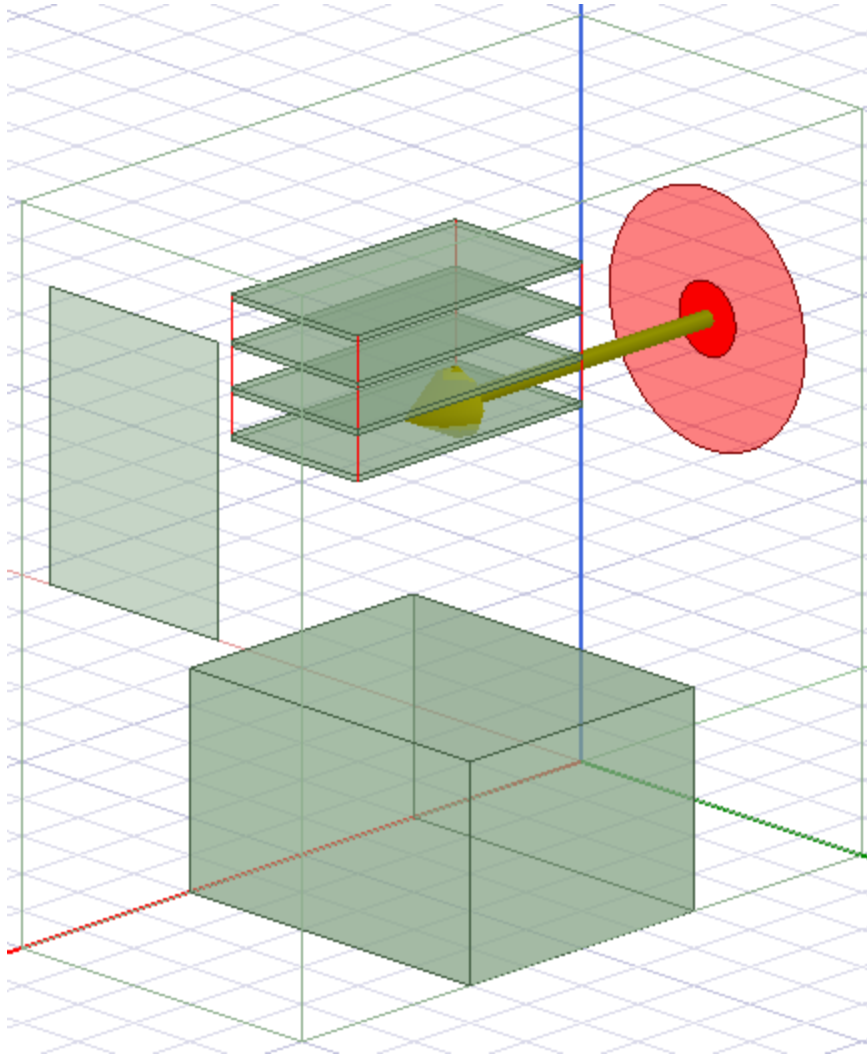

Figure 2-1: Model in the 3D Modeler window

3. From the **File** menu, select **Save As**, and save the project in the desired working directory.

Classic Icepak File Conversion Limitations

Reference the Icepak online help for detailed information on what is currently unsupported when opening an Icepak Classic project in the Electronics Desktop.

3 - Reviewing the Icepak Design

This chapter contains the following topics:

- [Geometry and Boundary Conditions](#)
- [Global Mesh Settings](#)
- [Mesh Regions](#)
- [Monitors](#)
- [Design Settings and Solution Setup](#)
- [Design Variables and Parametric Setup](#)
- [Postprocessing](#)
- [Fields Summary Report](#)

Geometry and Boundary Conditions

Classic Icepak objects are converted to geometry and, depending on the object, assigned a boundary condition or native component, which contains its thermal properties. Geometry is displayed in the **3D Modeler** window and listed in the history tree. Boundary conditions and Icepak native 3D components are displayed in the **Project Manager**.

1. View the image below, which displays a Classic Icepak fan object in the Project tree, Fans panel, and modeler window.

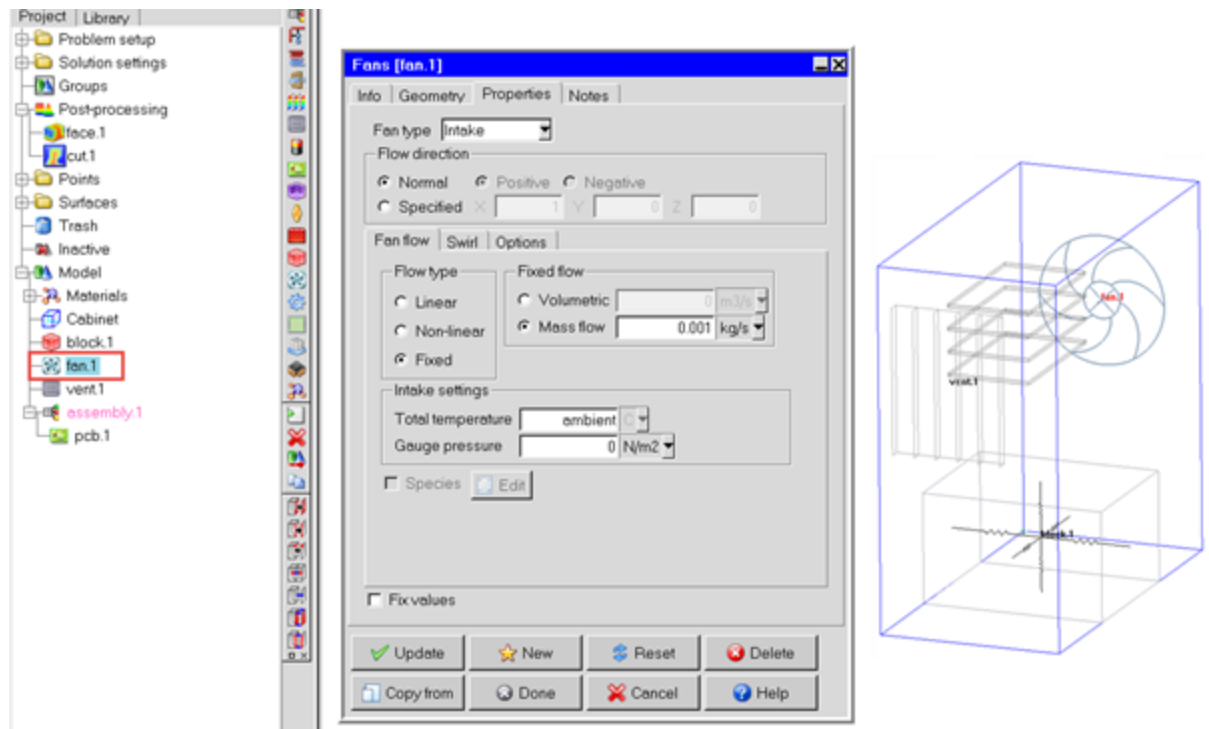

Figure 3-1: Classic Icepak Fan Object

2. In the Electronics Desktop, expand the model components in the history tree to view the geometry. Geometry selections in the history tree and highlighted as selections in the **3D Modeler** window.

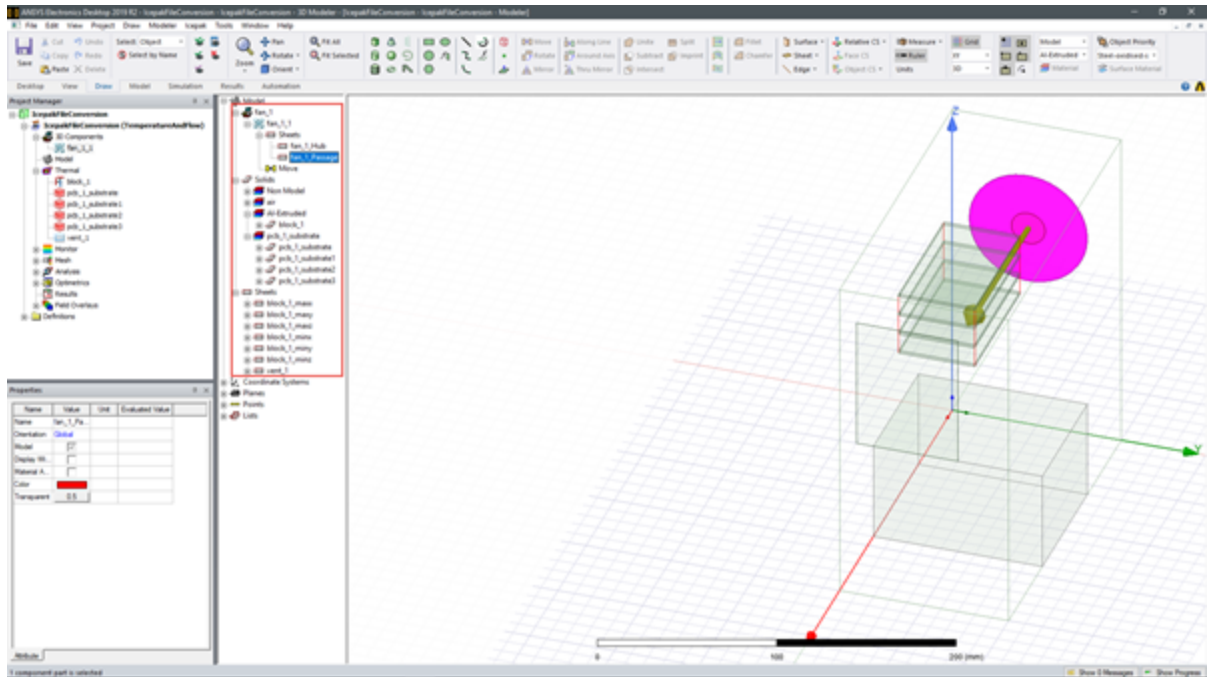

Figure 3-2: Model Geometry in the History Tree

3. In the **Project Manager**, expand **3D Components** to view the fan component and **Thermal** to view boundary conditions. Right-click on the fan component and select **Edit Definition** to view its thermal properties. Double-click on boundary conditions to view thermal properties.

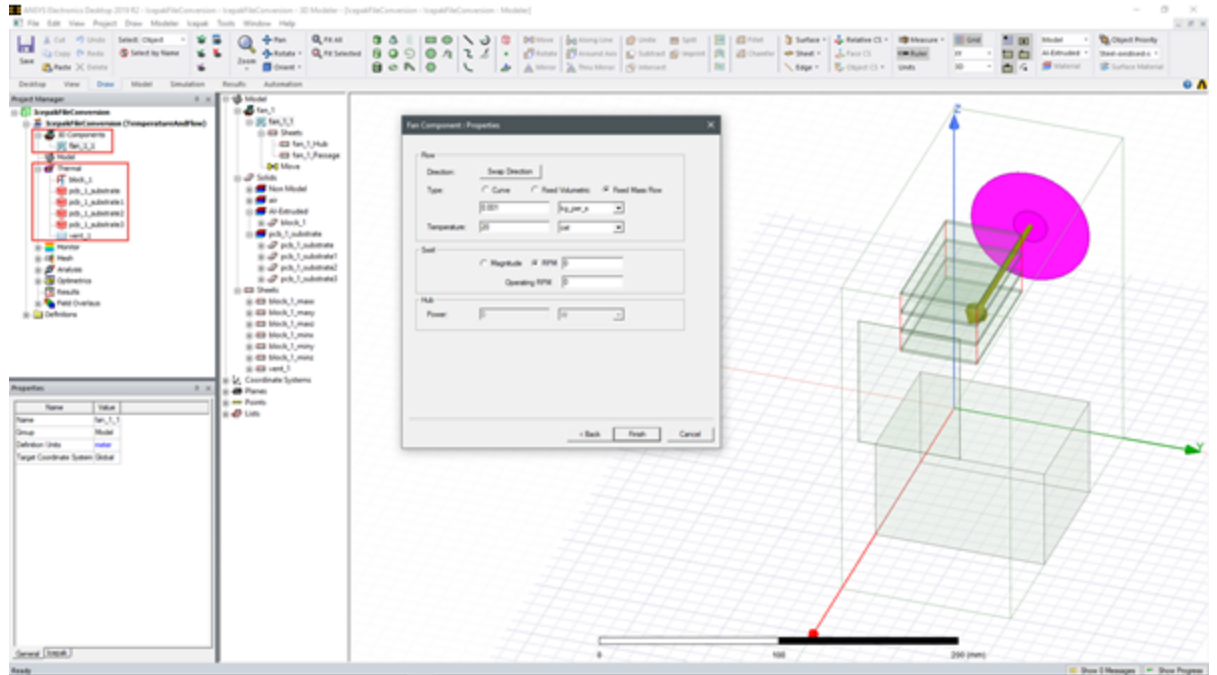

Figure 3-3: Boundary Conditions and Fan Component Dialog Box

Global Mesh Settings

Global mesh settings from the **Mesh control** panel in Classic Icepak are displayed in the **Mesh Region** dialog in the Electronics Desktop. After generating mesh in the Electronics Desktop, display controls and quality metrics are displayed in the **Mesh visualization** dialog.

1. View the image below, which displays the global **Mesh control** panel in Classic Icepak.

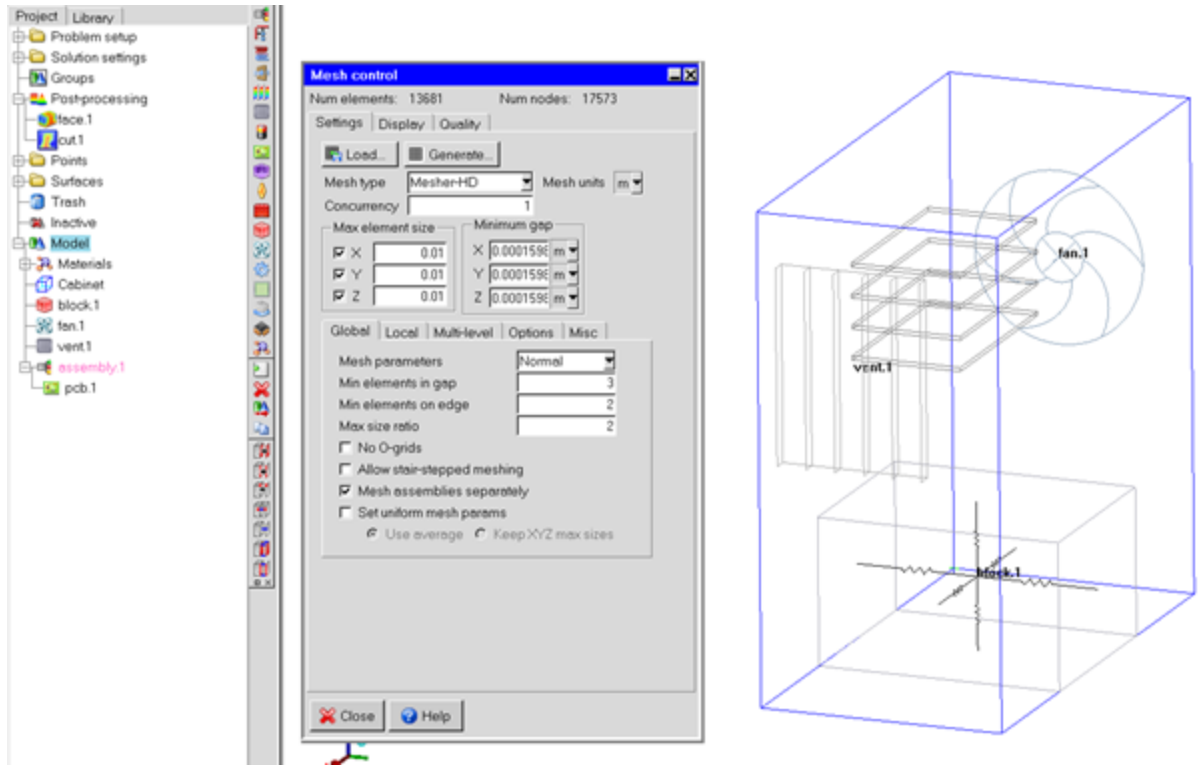

Figure 3-4: Classic Icepak Fan Object

2. On the **Simulation** ribbon, click **Global Mesh Settings**. Click the **Advanced** tab to view the global mesh settings.

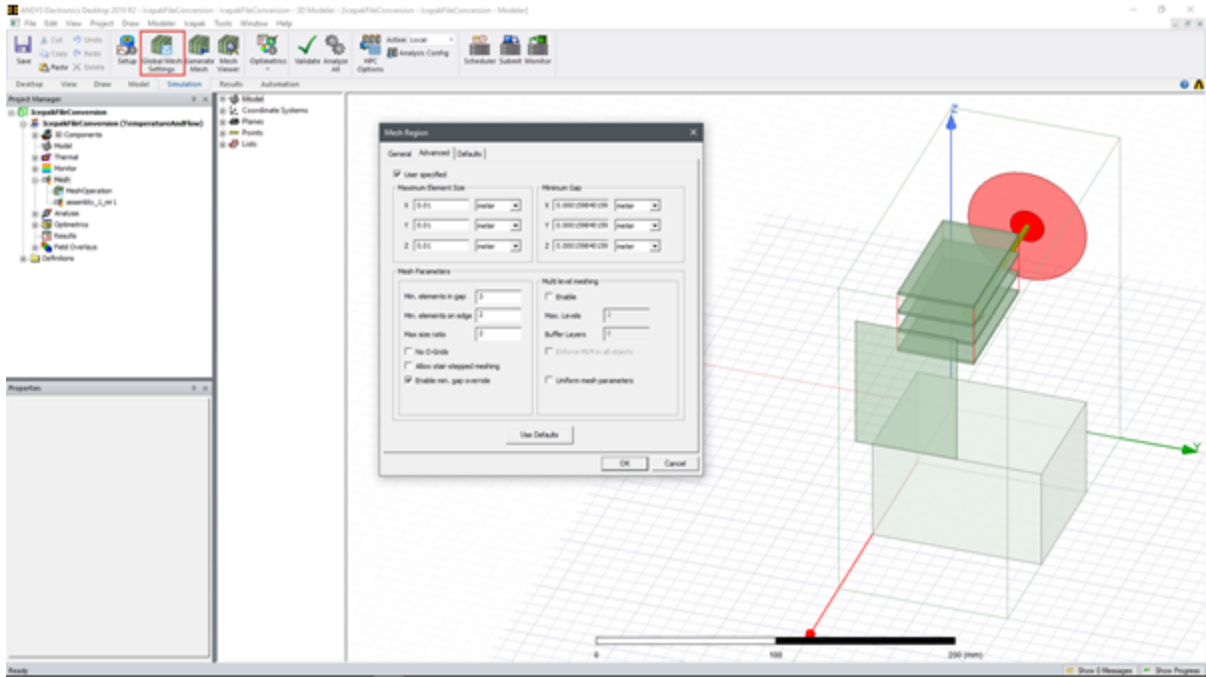

Figure 3-5: Model Geometry in the History Tree

- 3. On the **Simulation** ribbon, click **Mesh Viewer** to view the mesh visualization options and mesh quality metrics.

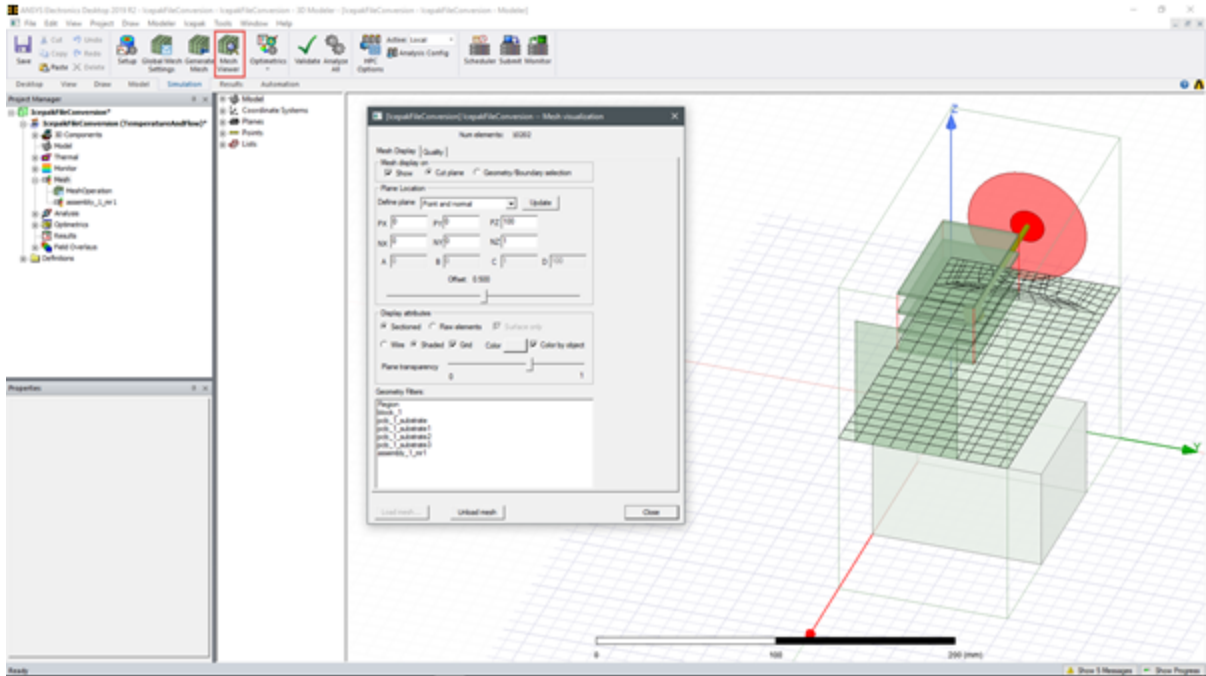

Figure 3-6: Mesh Visualization Display Tab

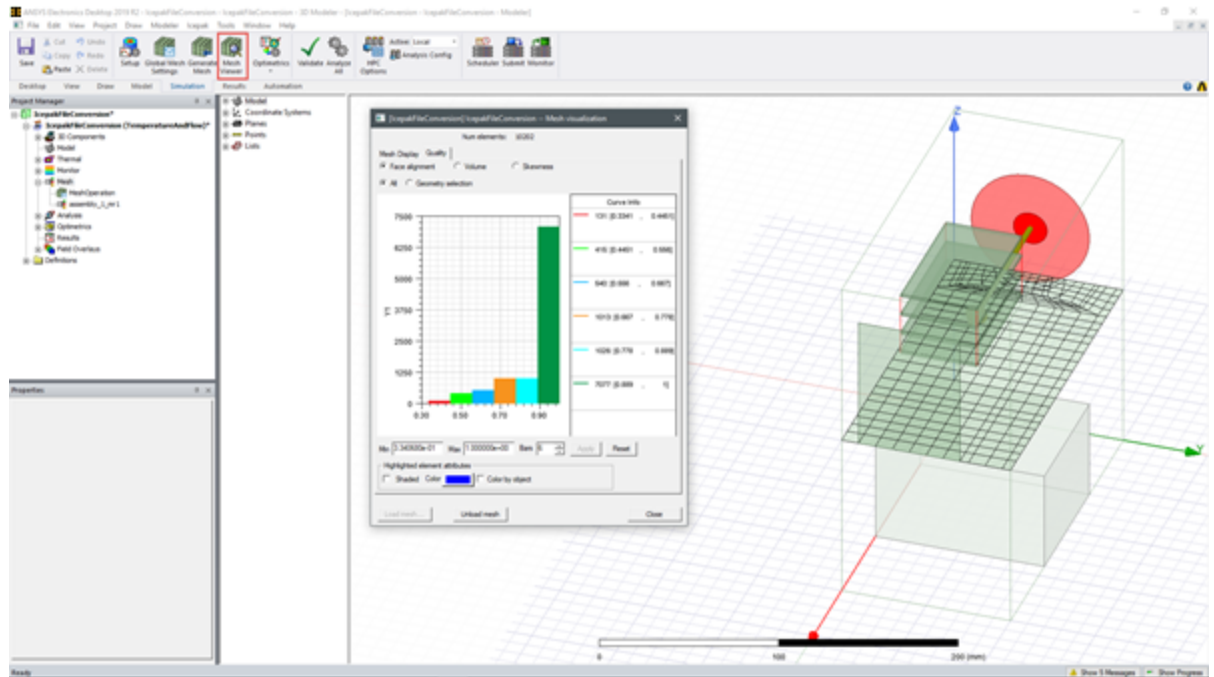

Figure 3-7: Mesh Visualization Quality Tab

Mesh Regions

Assemblies in Classic Icepak are converted as mesh regions in the Electronics Desktop. The mesh region has geometry, which is displayed in the history tree. The mesh settings are displayed in the **Mesh Region** dialog box, which can be accessed by double-clicking on the mesh region in the **Project Manager**.

1. View the image below, which displays the meshing options for a Classic Icepak assembly.

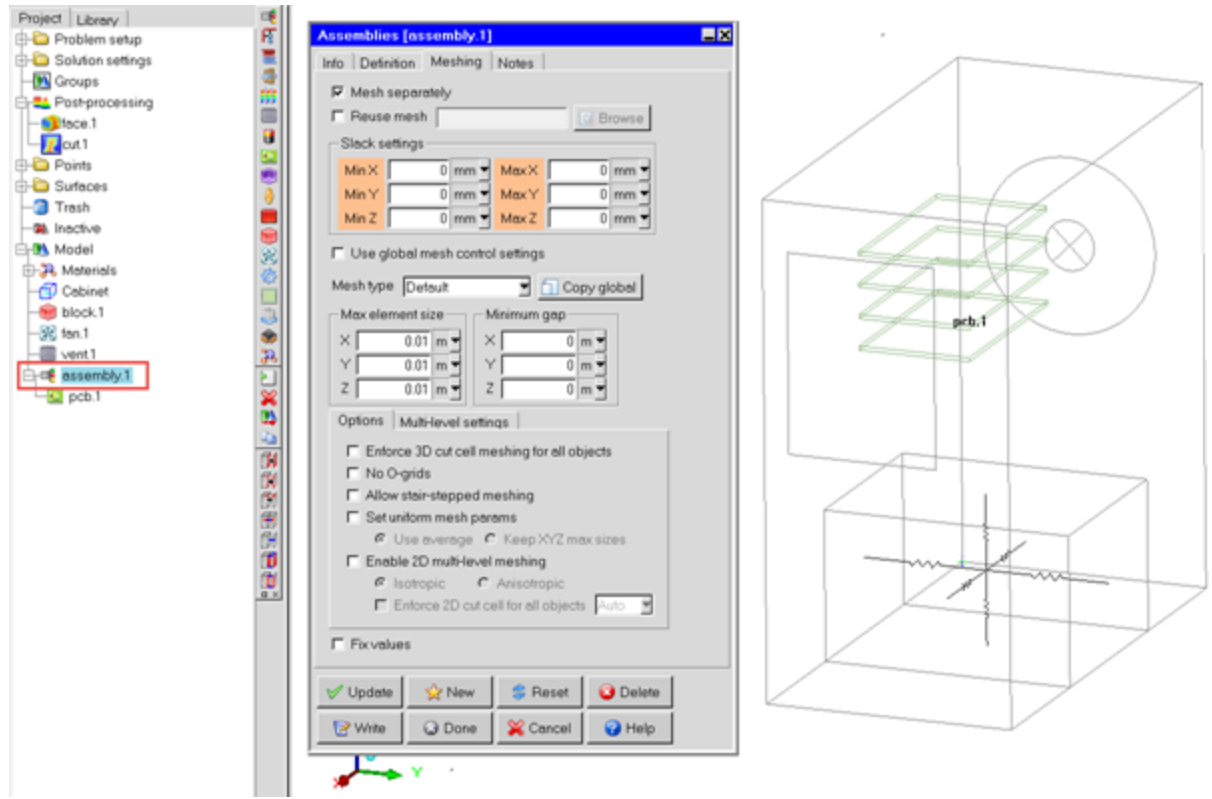

Figure 3-8: Classic Icepak Assembly Meshing Options

2. In the **Project Manager**, expand **Mesh** and double-click the mesh region. In the SubRegion dialog box, define padding settings to expand or shrink the mesh region. Then, in the **Mesh Region** dialog box, click the **Advanced** tab to view the region's mesh settings.

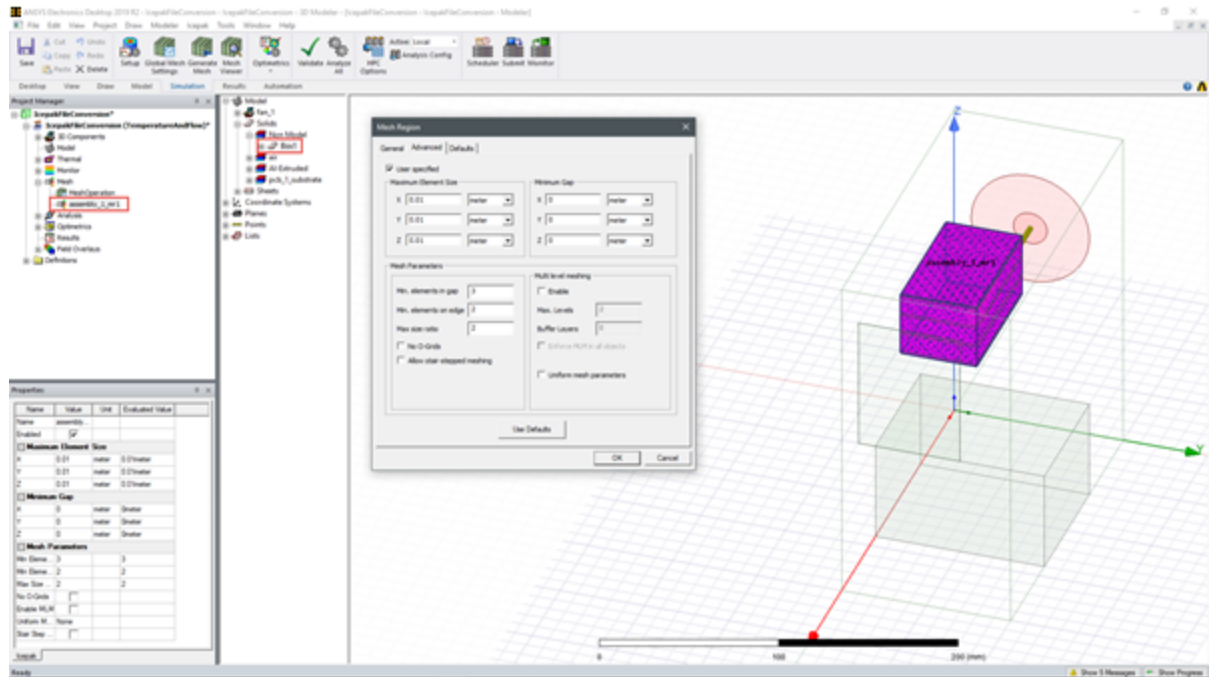

Figure 3-9: Mesh Region Options

Monitors

Point monitors in Classic Icepak are converted to the Electronics Desktop and are displayed in the 3D modeler window. Point monitors are listed under **Monitor** in the **Project Manager**, and geometry is displayed in the history tree. The monitor point settings are displayed in the **Monitor Setup** dialog.

1. View the image below, which displays a monitor point in Classic Icepak.

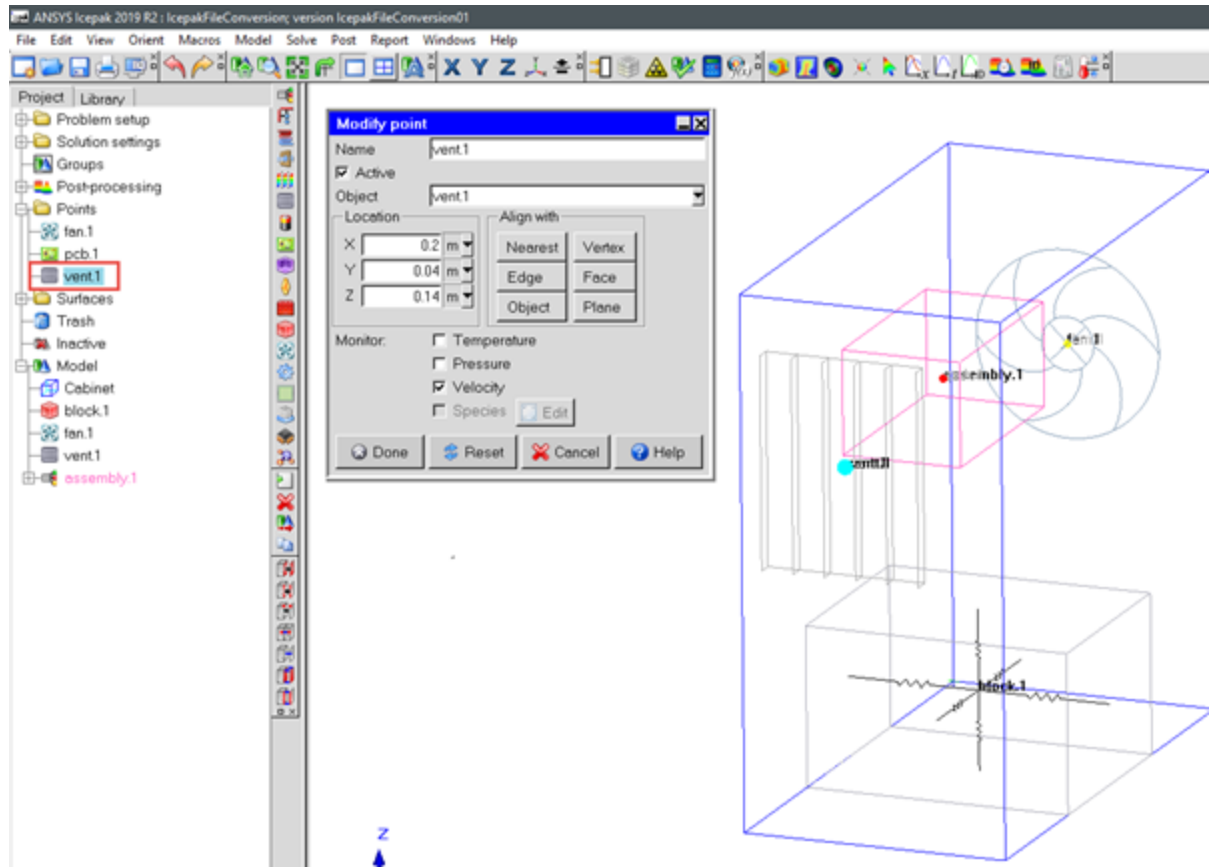

Figure 3-10: Classic Icepak Monitor Options

2. In the **Project Manager**, expand **Monitor** and double-click a point monitor. In the **Monitor Setup** dialog box, review the point monitor's settings.

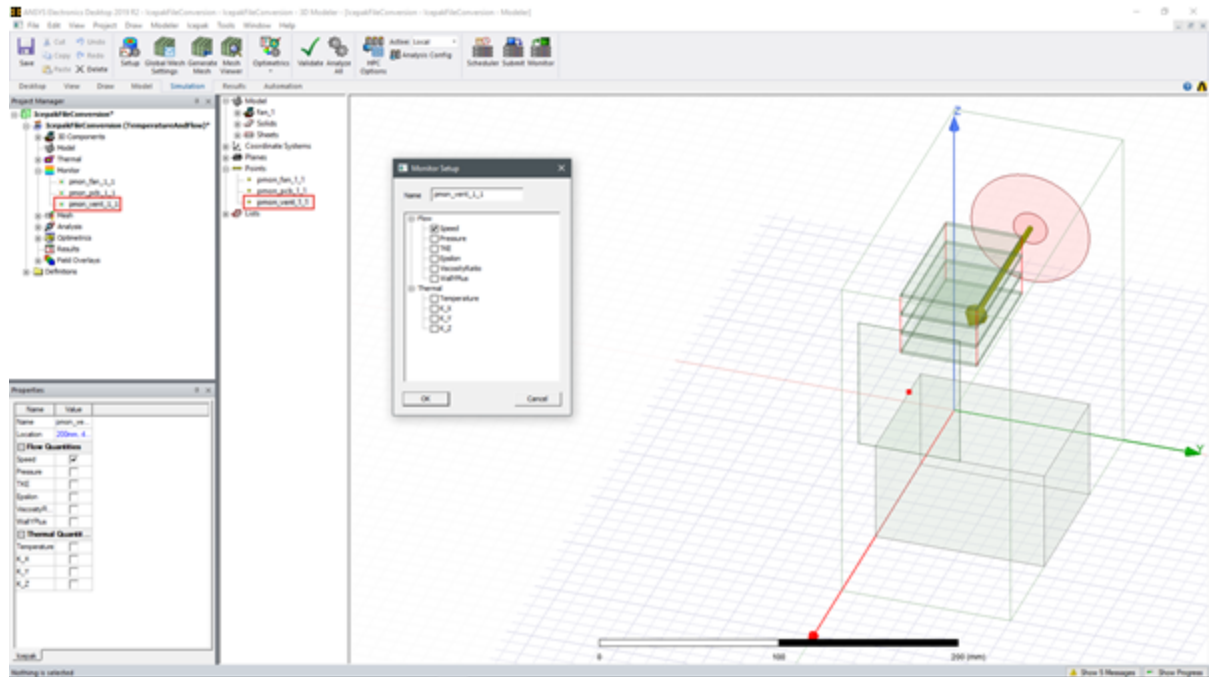

Figure 3-11: Monitor Setup Options

Design Settings and Solution Setup

Classic Icepak **Basic settings**, **Advanced settings**, and **Basic parameters** are displayed in the **Design Settings** dialog and **Icepak Solve Setup Dialog** in the Electronics Desktop.

1. View the images below, which display Icepak **Basic settings**, **Advanced Settings**, and **Basic parameters**.

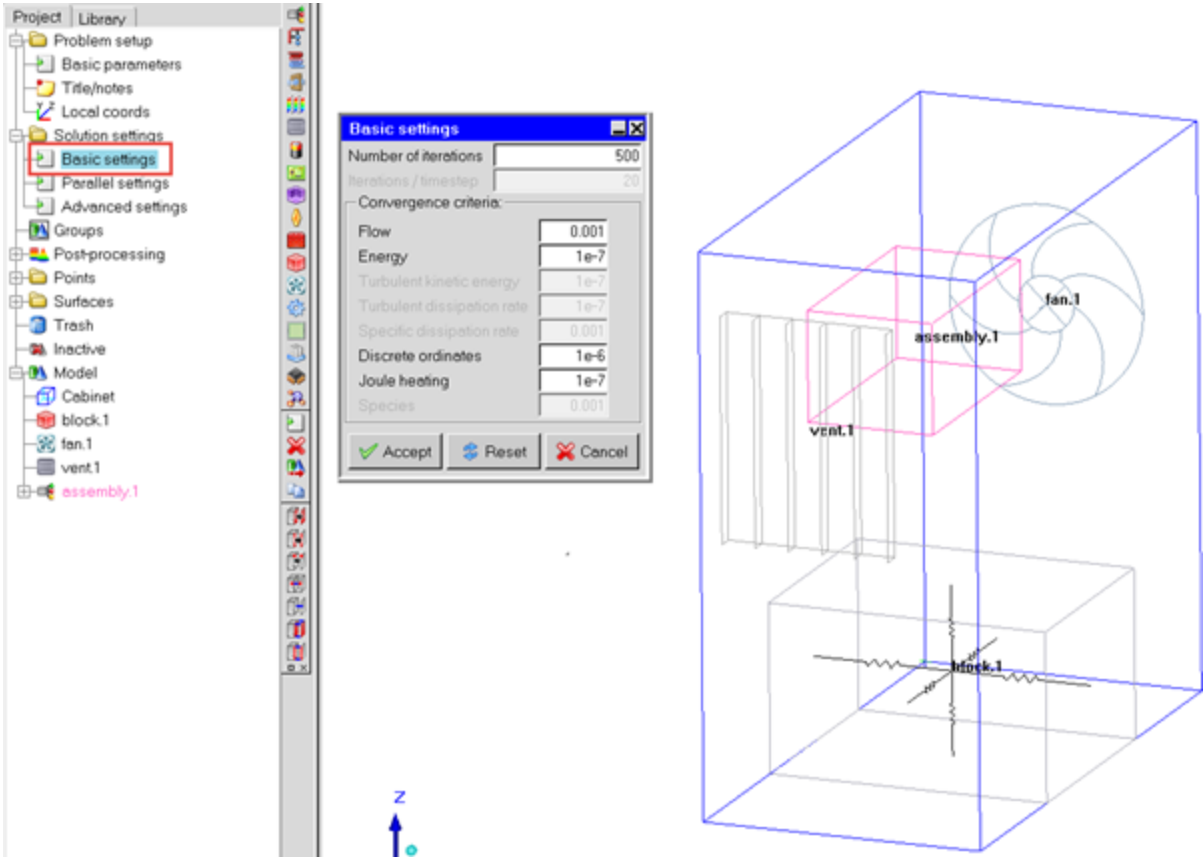

Figure 3-12: Classic Icepak Basic Settings

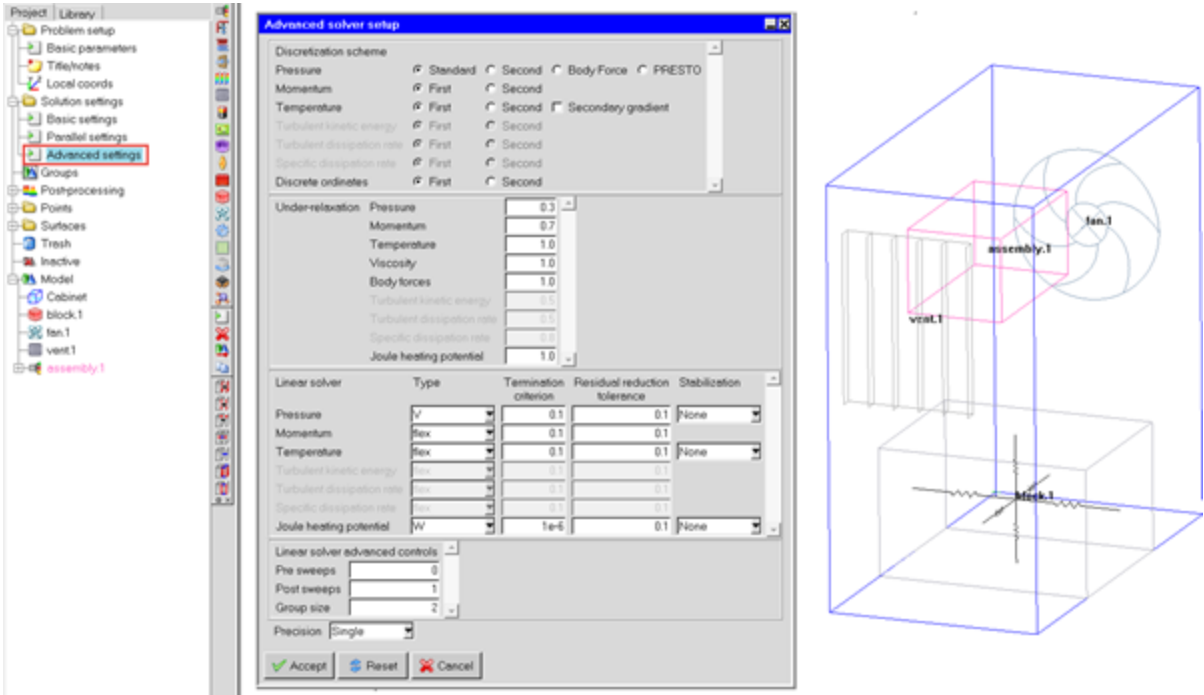

Figure 3-13: Classic Icepak Advanced Settings

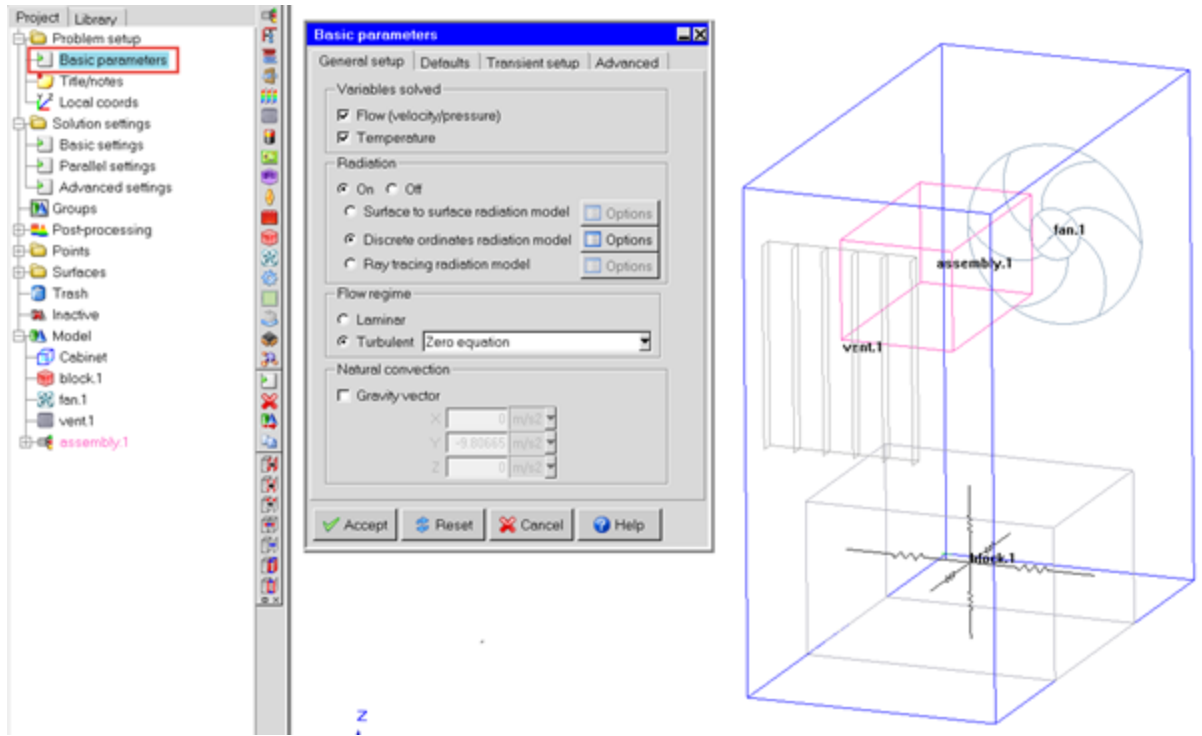

Figure 3-14: Classic Icepak Basic Parameters

- From the **Icepak** menu, click **Design Settings** to view the **Ambient Conditions** and **Gravity** settings.

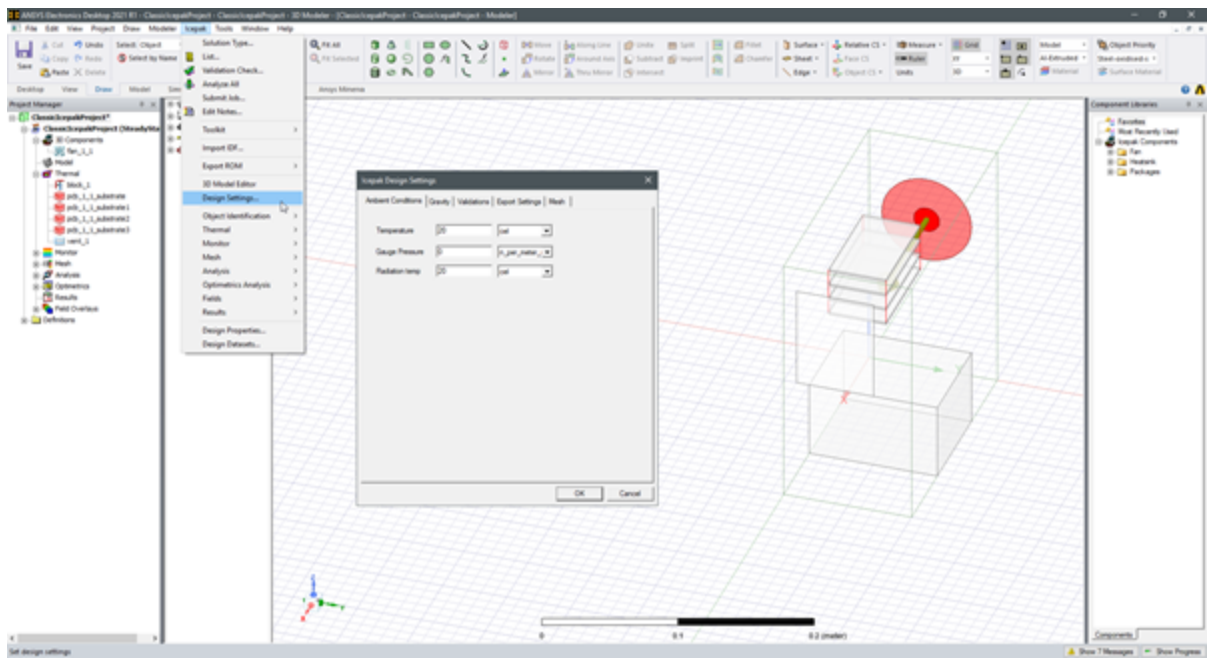

Figure 3-15: Design Settings - Ambient Conditions Tab

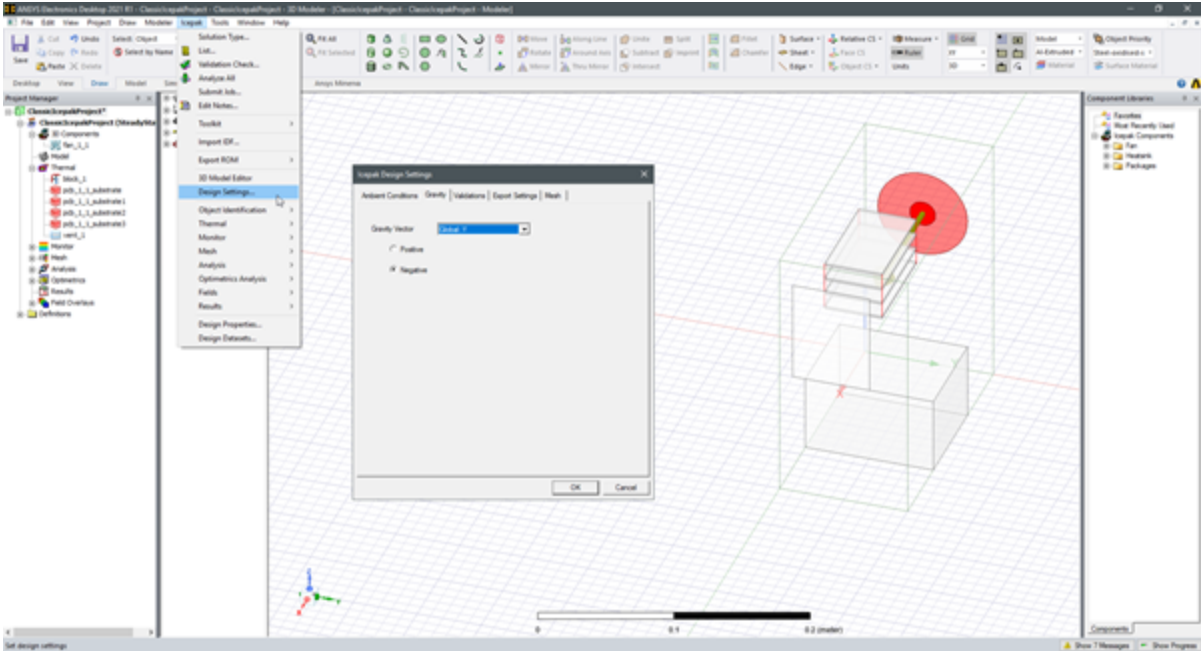

Figure 3-16: Design Settings - Gravity Tab

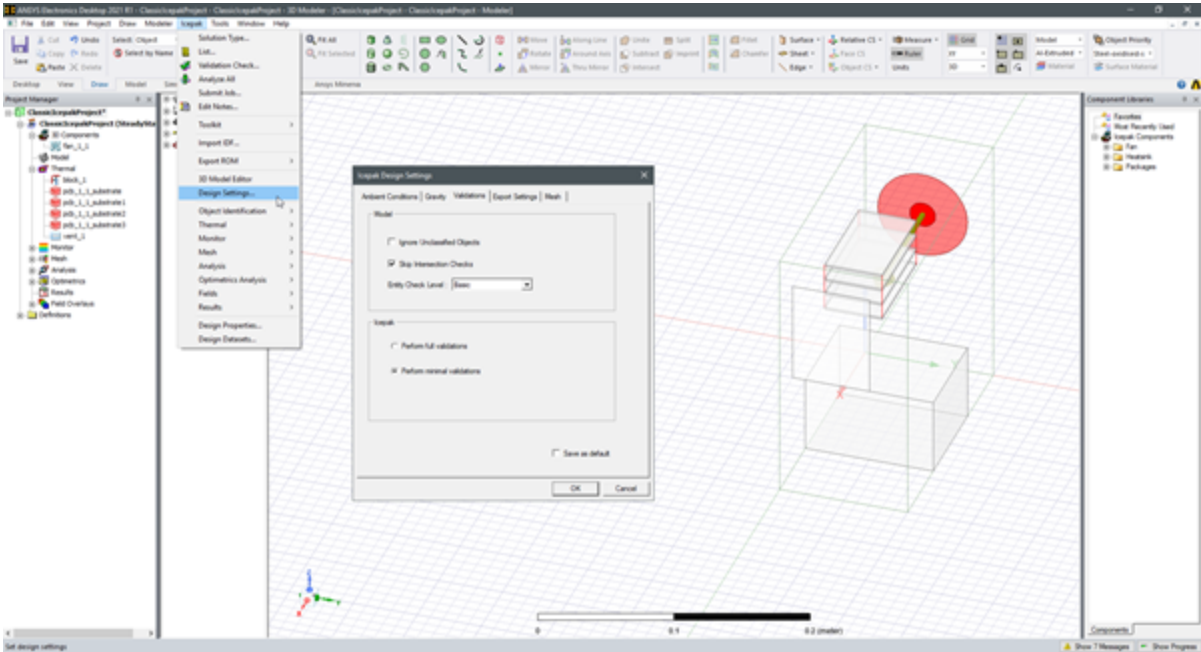

Figure 3-17: Design Settings - Validations Tab

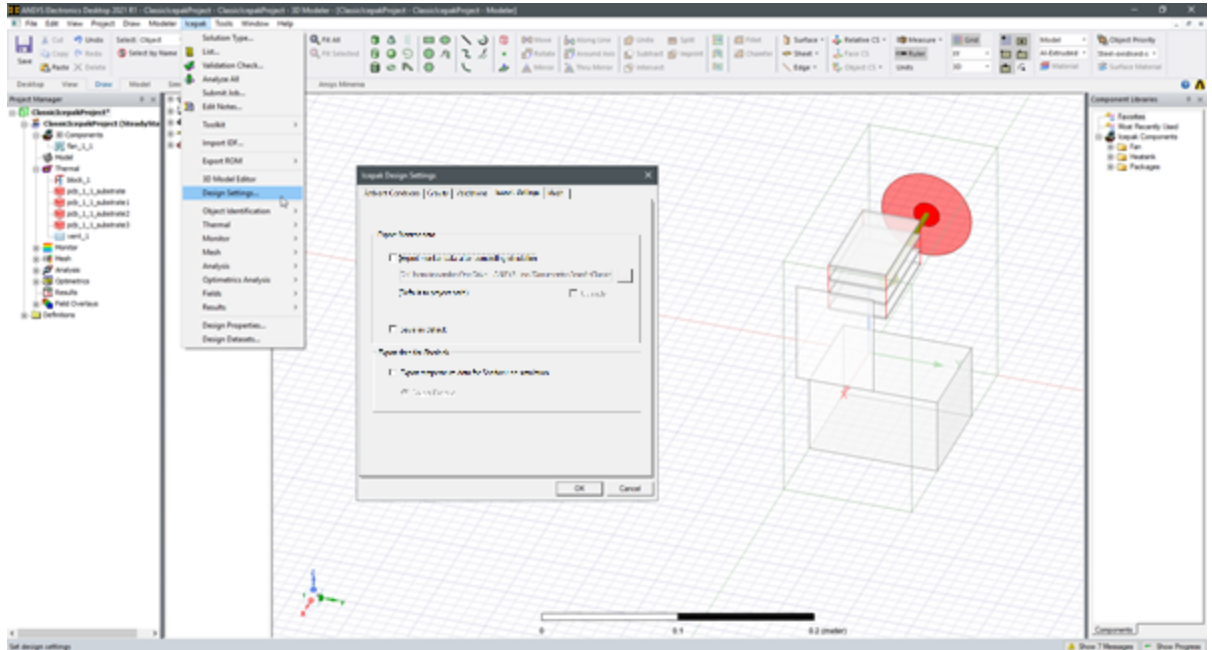

Figure 3-18: Design Settings - Export Settings Tab

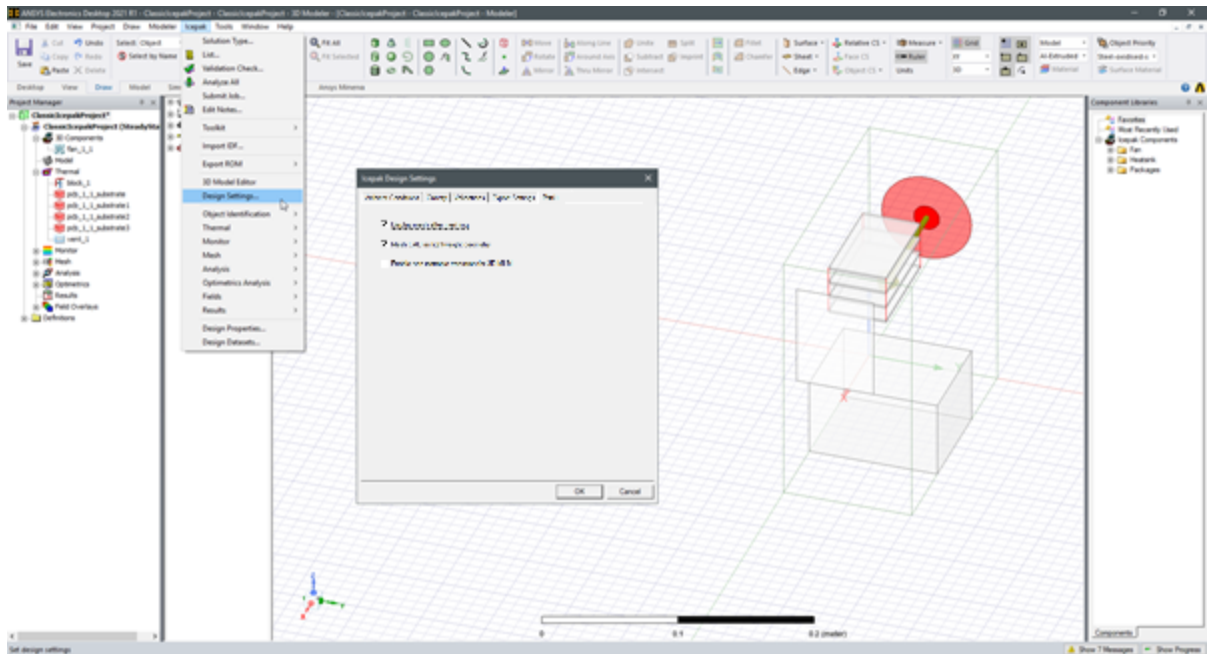

Figure 3-19: Design Settings - Mesh Tab

3. In the **Project Manager**, expand **Analysis** and double-click the solution setup to view the **General** settings, **Convergence** settings, **Solver Settings**, and **Radiation** settings.

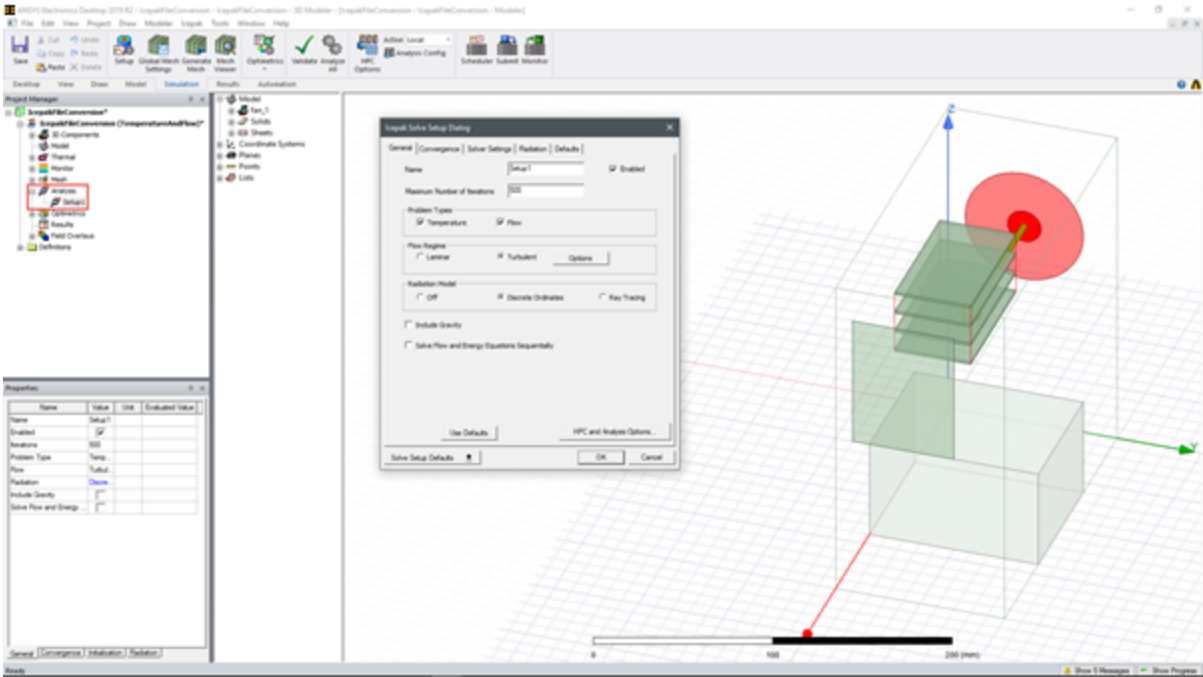

Figure 3-20: Icepak Solve Setup Dialog - General Tab

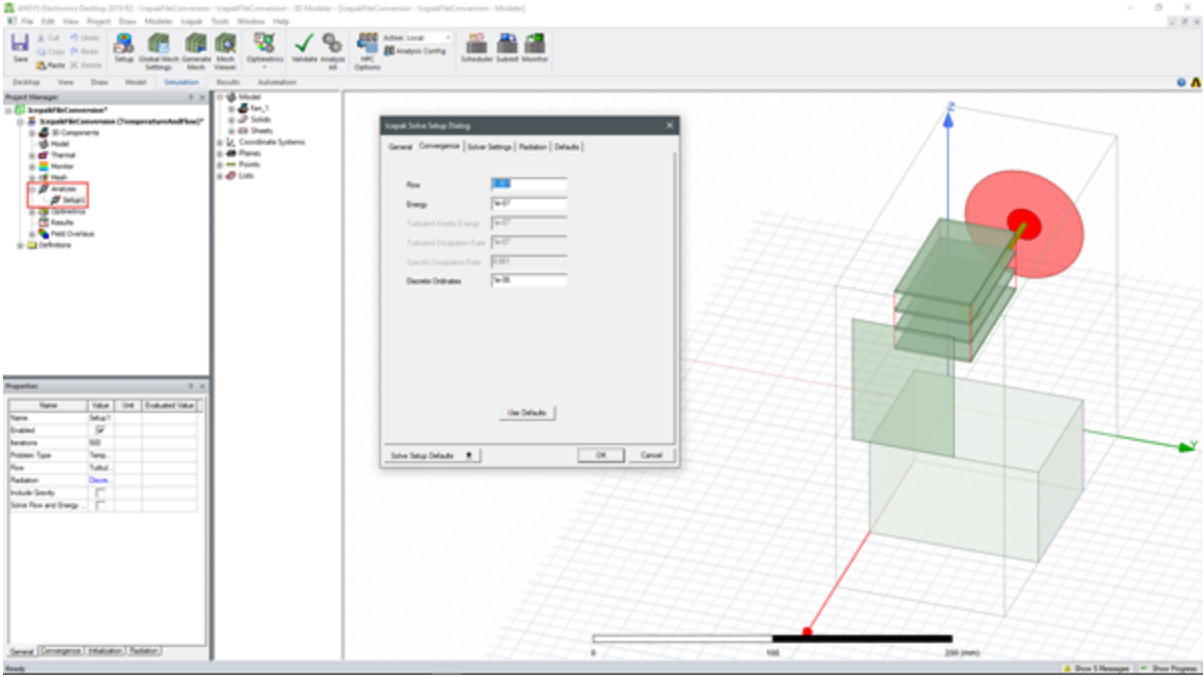

Figure 3-21: Icepak Solve Setup Dialog - Convergence Tab

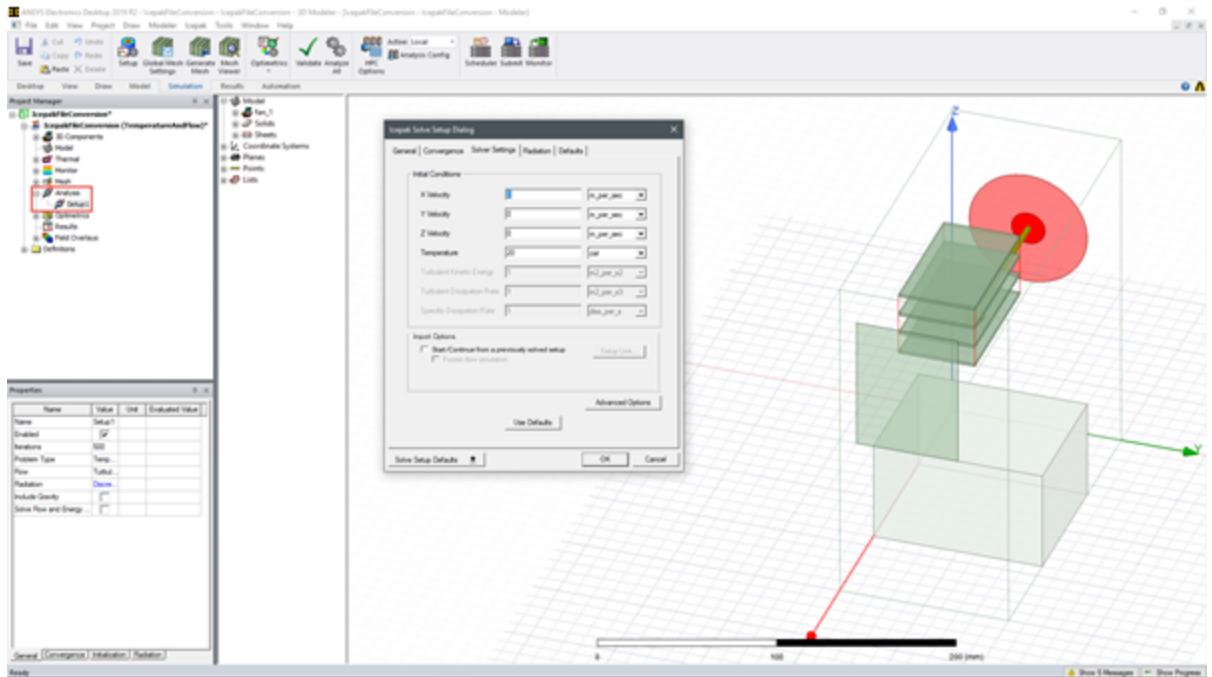

Figure 3-22: Icepak Solve Setup Dialog - Solver Settings Tab

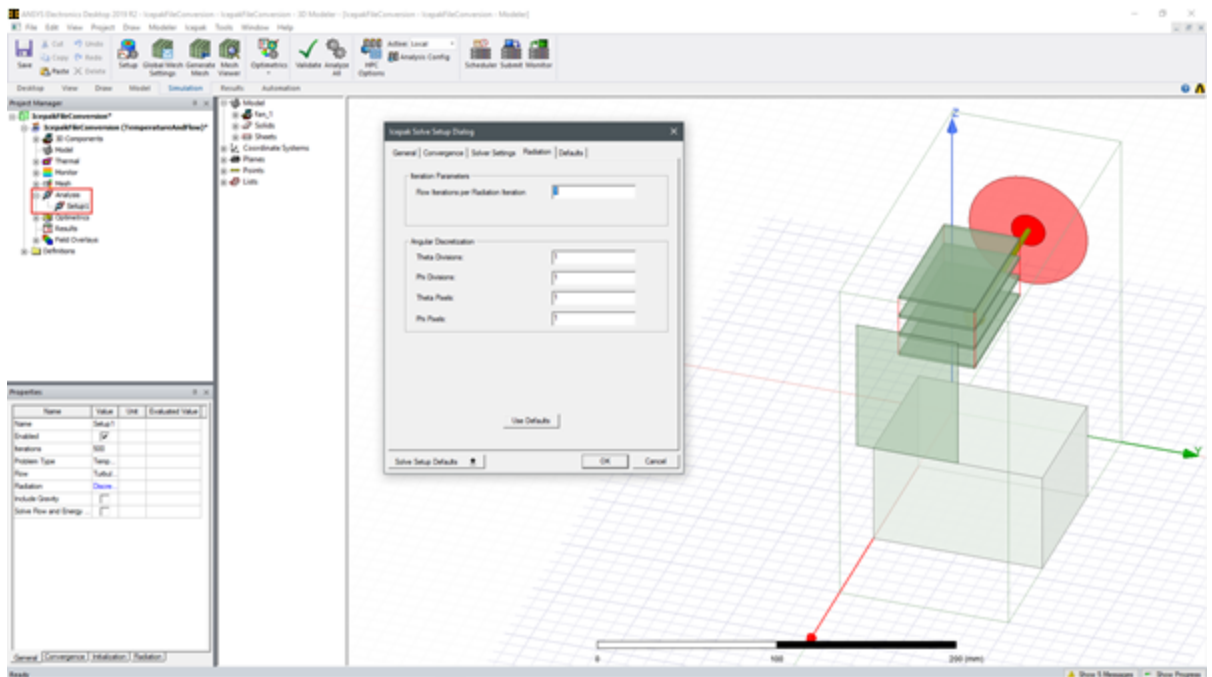

Figure 3-23: Icepak Solve Setup Dialog - Radiation Tab

Design Variables and Parametric Setup

Design variables from the Classic Icepak project are displayed in the **Properties** dialog in the Electronics Desktop. Classic Icepak parametric trials are displayed in the **Setup Sweep Analysis** dialog.

- 1. View the images below, which display Icepak design variables and parametric trials.

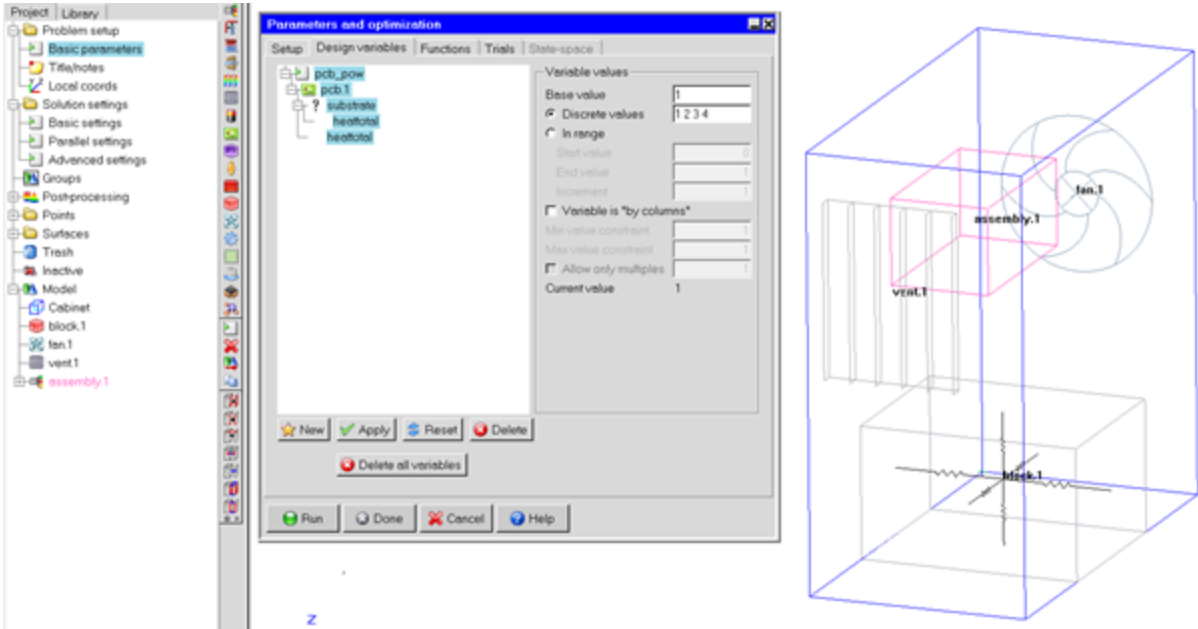

Figure 3-24: Classic Icepak Design Variables

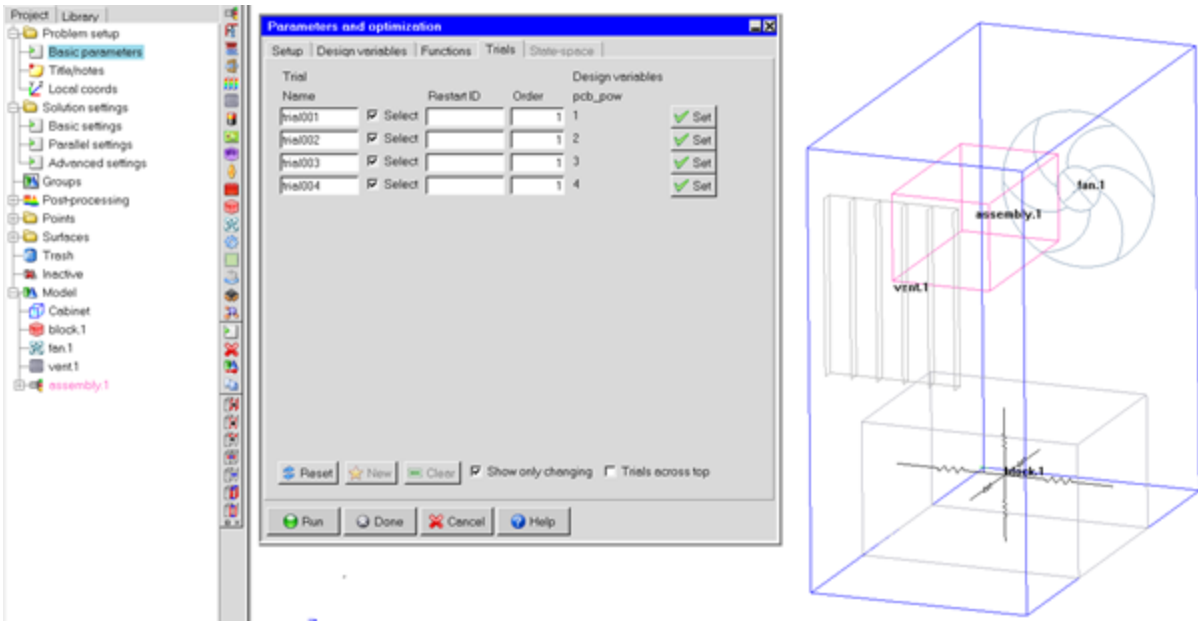

Figure 3-25: Classic Icepak Parametric Trials

- From the **Project** menu, click **Project Variables** to view the project variables in the **Properties** dialog box.

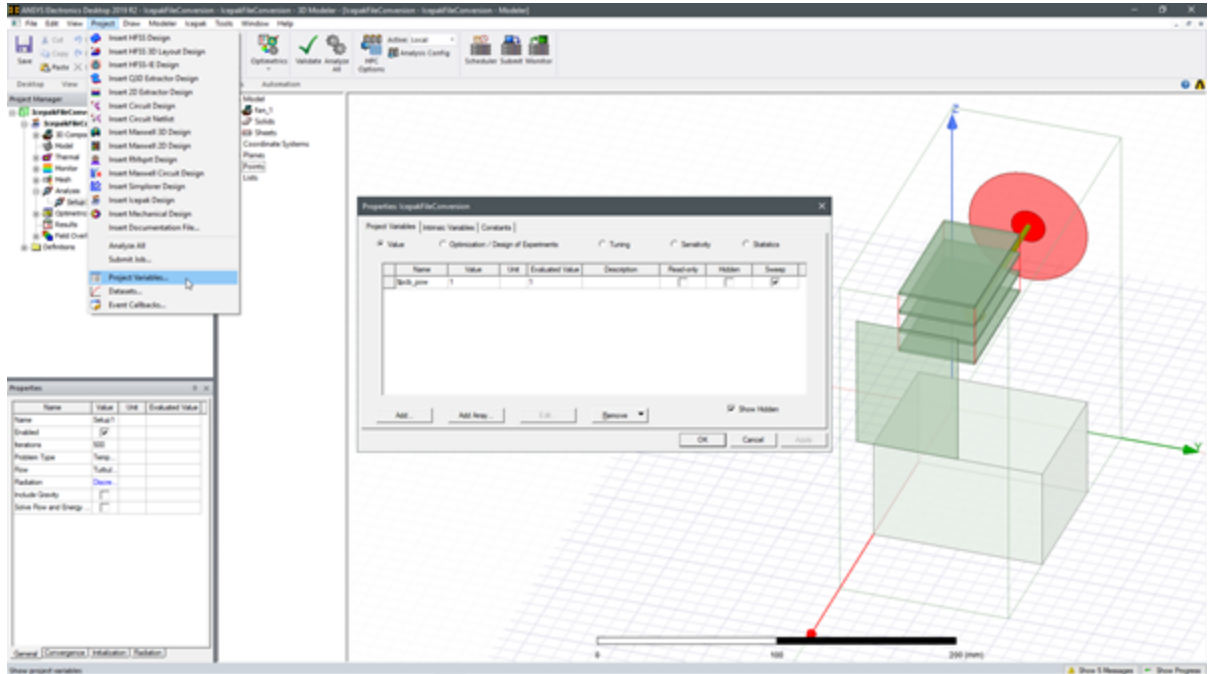

Figure 3-26: Icepak Parametric Trials

- In the **Project Manager**, expand **Thermal** and double-click the a block boundary condition. Note the variable in the **Total Power** definition.

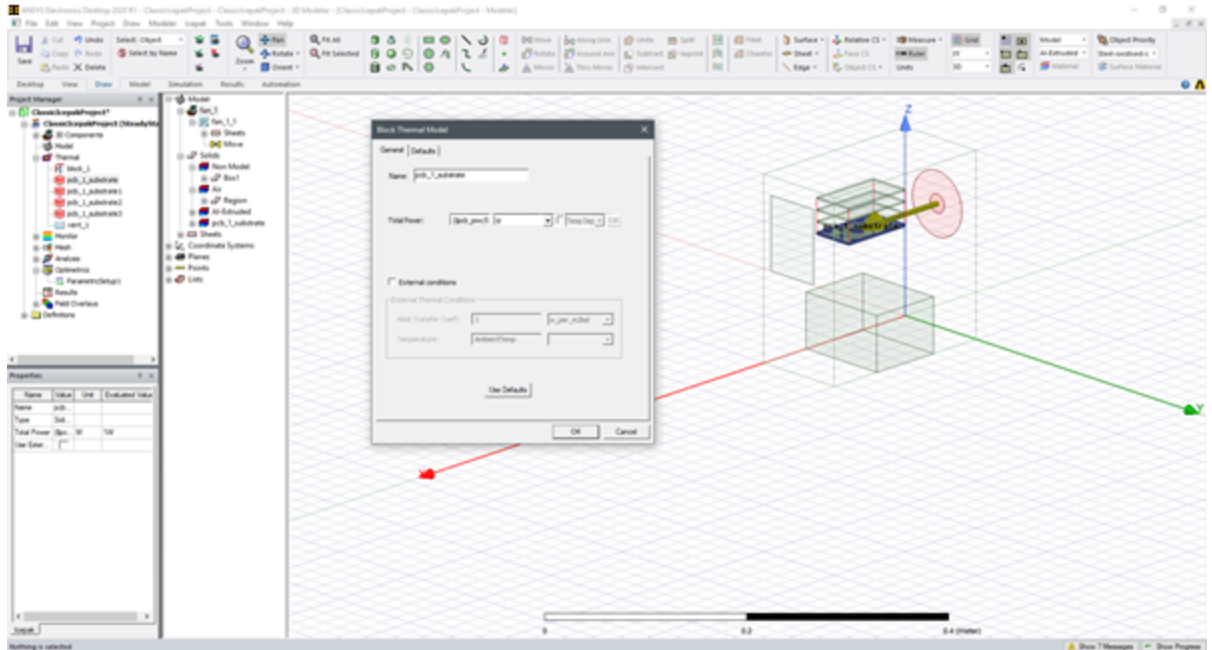

Figure 3-27: Icepak Variable in Block Boundary Condition

4. In the **Project Manager**, expand **Optimetrics** and double-click the parametric setup to open the **Setup Sweep Analysis** dialog box. Review the trials defined on the **Sweep Definitions** tab.

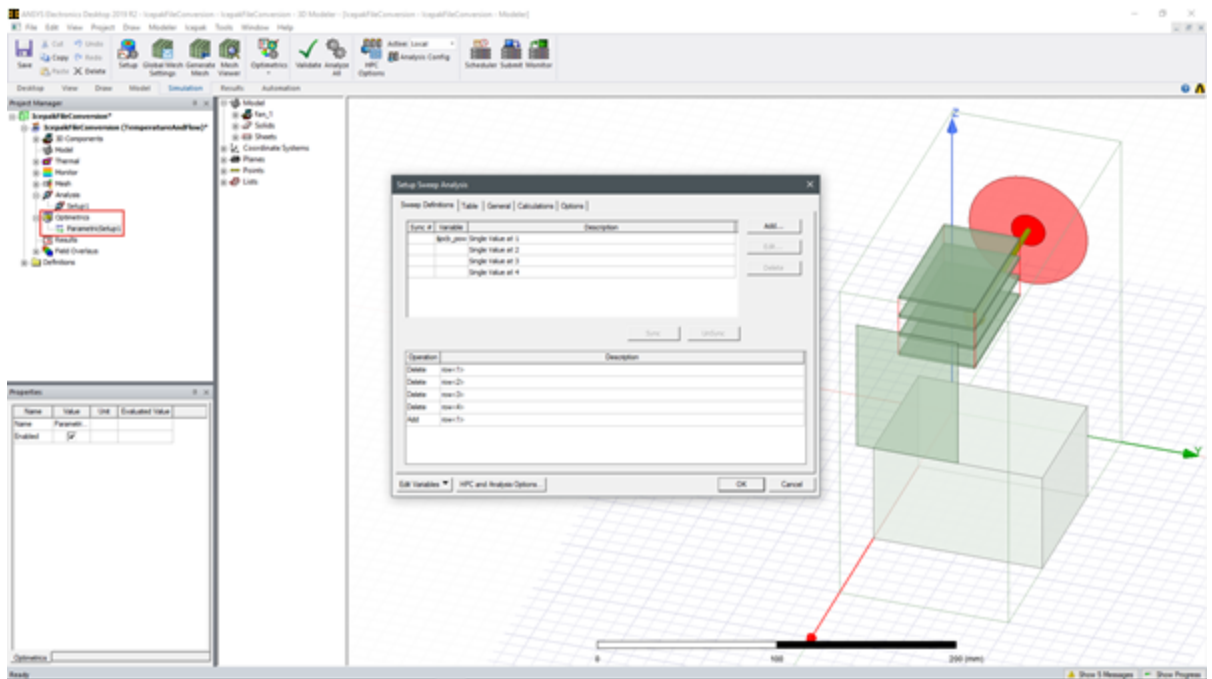

Figure 3-28: Icepak Sweep Setup

Postprocessing

Post-processing objects from the Classic Icepak project are displayed in the **3D Modeler** window and are listed under **Field Overlays** in the **Project Manager**.

1. View the image below, which displays a plane cut of velocity vectors in Classic Icepak.

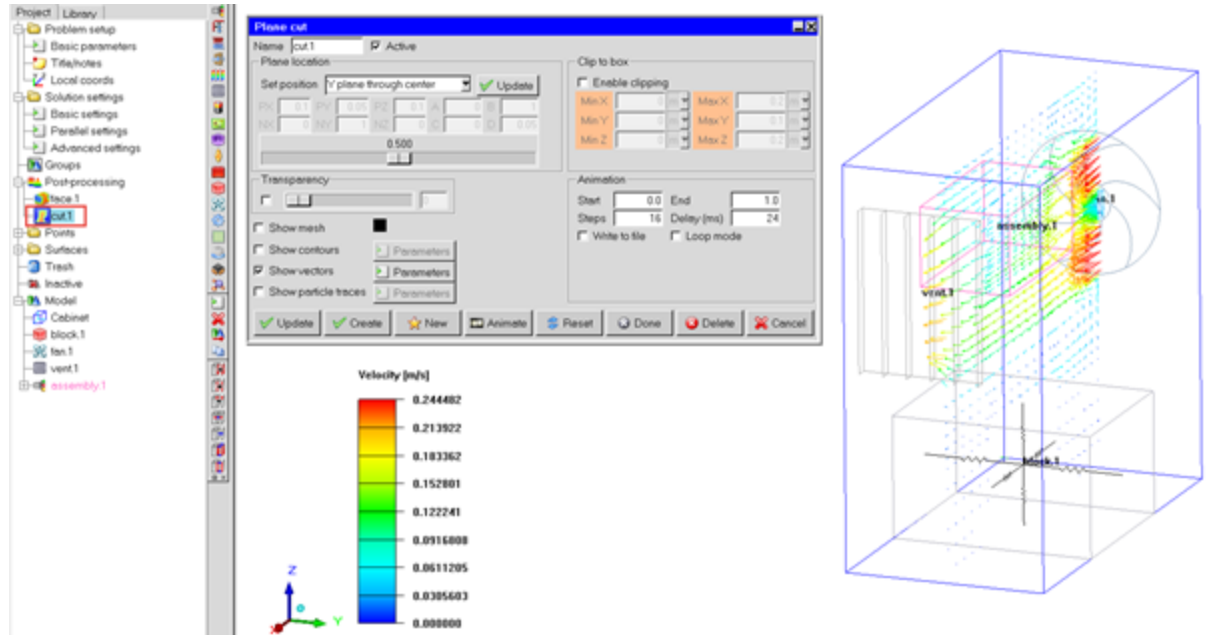

Figure 3-29: Classic Icepak Velocity Vectors Plane Cut

2. In the **Project Manager**, expand **Field Overlays** to display the defined overlays. Expand one, right-click on the overlay, and select **Modify Field Plot** to view the definition in the dialog box.

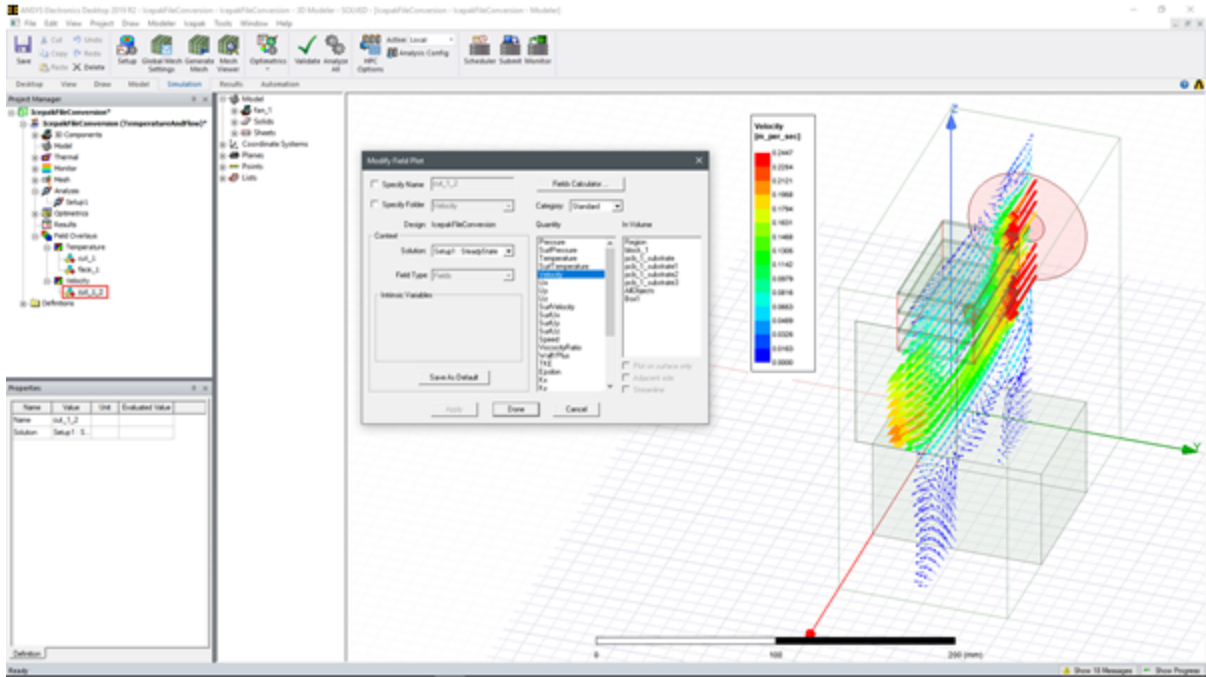

Figure 3-30: Icepak Field Plot - Velocity Vectors Plane Cut

Fields Summary Report

A Classic Icepak summary report is converted to a fields summary in the Electronics Desktop.

1. View the image below, which displays a summary report in Classic Icepak.

